

USER MANUAL

SIMRIG SR1/SR2/SR3

EN

SIMRIG AB

Torkelsbohögsvägen 11
43741 Lindome
Sweden

info@simrig.se
+46 760 22 45 50

March 27, 2024

For the most up-to-date version please visit: www.simrig.se

Contents

1	Warning	5
2	Limitations	6
3	System Requirements	7
4	Parts List	8
4.1	Cables	8
4.2	Hardware	8
5	Electronic Control Unit	10
5.1	Fuses	10
5.2	Cooling	10
5.3	Ports	10
6	Actuator	12
7	Power Supply Unit	13
8	Emergency Stop	14
8.1	Error Code	14
9	Assembly	16
9.1	What you need	16
9.2	Measurements	16
9.3	Before you start	16
9.4	Install the actuators using 780x20x20 aluminium profiles	17
9.5	Install the actuators using the EasyBracket	28
9.6	Install the Electronic Control Unit	38
9.7	Install the Emergency Stop	39
9.8	Electrical	40
9.9	Adjustments	46
10	Software and Drivers	47
10.1	First start	48
10.2	Game configuration	49

10.3 Profiles	49
10.4 Axis tester	50
10.5 Load estimator	50
11 Maintenance	51
11.1 Cleaning	51
11.2 Periodic checks	51
11.3 Fuse replacements	51
12 Technical Support	52
12.1 Manufacturer	52

1 Warning

Make sure no children or pets are in the vicinity of the motion system before and during operation.

The actuators are very power full. They are able to inflict serious damage to both living creatures and things.

After a long period of use the motors can get too hot to touch. Do not remove the covers. Do not touch the motors.

Locate the emergency stop and in a easy to reach position. Test emergency stop after assembly.

At all times keep your body parts over the rig frame. Never under where they can get pinched/crushed.

Make sure that the rig and the peripherals attached to it have enough room to move freely without hitting anything or crushing/pinching any living thing. Beware that the motion system moves up and down, and tilts both sideways, and leans forward and backward.

Never disassemble or modify the actuators, the power supply, or the cables. Disassembly of the power supply puts you at risk of high voltage. Disassembly of the actuators puts you at risk of injury. Furthermore, the actuators are factory calibrated. Disassembly ruins the calibration.

2 Limitations

The SIMRIG motion systems are not toys. Never let any children, seniors, or untrained persons operate the motion system.

The maximum load actuated by the motion system shall never exceed 175 kg (SR1), 225 kg (SR2), or 250 kg (SR3.) This includes the driver, the rig, and all accessories.

For indoor use only. Do not operate above 5000 m from sea level. Do not operate above 40 °C ambient or below 15 °C.

The power supply must be connected to an earthed socket.

Only one person at a time may operate the motion system or sit on the rig.

May only be used on a flat surface.

Do not modify the system or parts thereof. Do not modify the cables. Do not add sleeves to the cables.

3 System Requirements

A sim rig made of aluminium extrusion of size 40x40, 80x40, 120x40, or 160x40. Other dimension are available on request. The maximum rig width is 620 mm unless EasyBrackets are used. See www.simrig.se/hw for details.

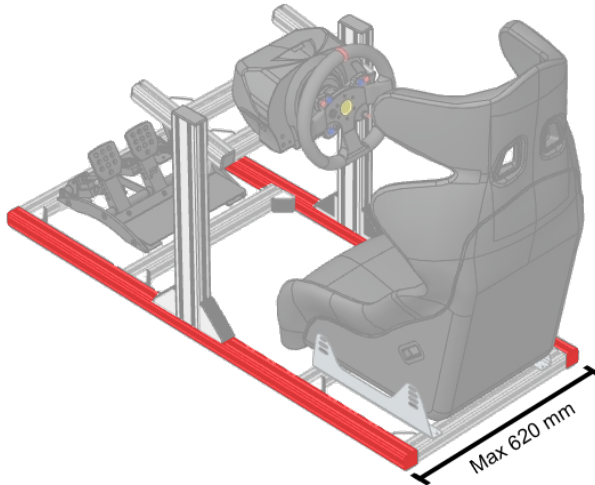

Figure 1: The maximum rig width is 620 mm unless EasyBrackets are used.

The total weight of everything actuated by the motion system must be less than 175 kg (SR1), 225 kg (SR2), and 250 kg (SR3) respectively. This includes the driver, rig, peripherals, screens etc.

A modern PC with:

- Windows 10 or 11 (64-bit)
- An Intel i5 CPU or equivalent

4 Parts List

- 4x SIMRIG actuators
- 1x Electronic Control Unit (ECU)
- 1x Power Supply Unit (PSU)
- 1x Emergency stop
- 4x Support brackets
- 4x Vibration dampers

4.1 Cables

- 1x 100-220V power cable (C13)
- 1x Low voltage power cable (2 m)
- 4x Linear actuator cable (0.8 m)
- 1x USB cable (3 m)

4.2 Hardware

- 10x M5x25 mm screw
- 2x M5x14 mm screw
- 4x M5I8 T-nut
- 8x Plastic spacer
- 8x M5 locknut
- 8x M5 washer
- 10x Cable ties
- 6x Cable clips

4.2.1 Mounting with 20x20 profiles

- 4x 780x20x20 profiles
- 8x Plastic end-cap
- 8x 90 degree angle bracket
- 8x M8x16 mm screw
- 8x M8I8 T-nut
- 16x M5x25 mm screw
- 24x M5I5 T-nut

- 8x M5I8 T-nut
- 8x M5x14 mm screw
- 8x M5x8 screw

4.2.2 Mouting with EasyBracket

- 8x M8x80 mm screw
- 8x Nordlock washer
- 8x M8x16 mm screw
- 8x M8I8 T-nut

5 Electronic Control Unit

The *Electronic Control Unit* (ECU) contains for motor controllers and all electronics necessary to interpret and act on motion commands sent by your PC.

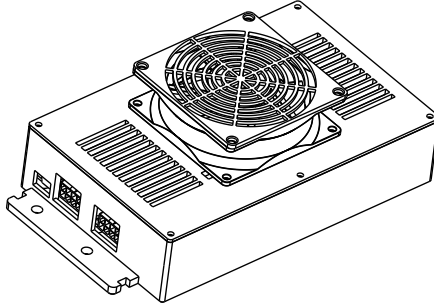

5.1 Fuses

The ECU contains four Mini Blade fuses rated at 7.5 A. Replacements are available at your local automotive parts store. For reference see Little Fuse part nr. *029707.5WXNV*.

Located next to each fuse is an LED. This LED lights up red if the fuse is blown (power is required for this test.) A blown fuse results in an error code.

5.2 Cooling

An 80 mm fan keeps the ECU cool. This fan is temperature controlled and only enabled when necessary. If the ECU becomes warm even when the fan is running it enters a high-efficiency mode. In this mode the motors are more audible. Before overheating the ECU shuts down with an error code.

5.3 Ports

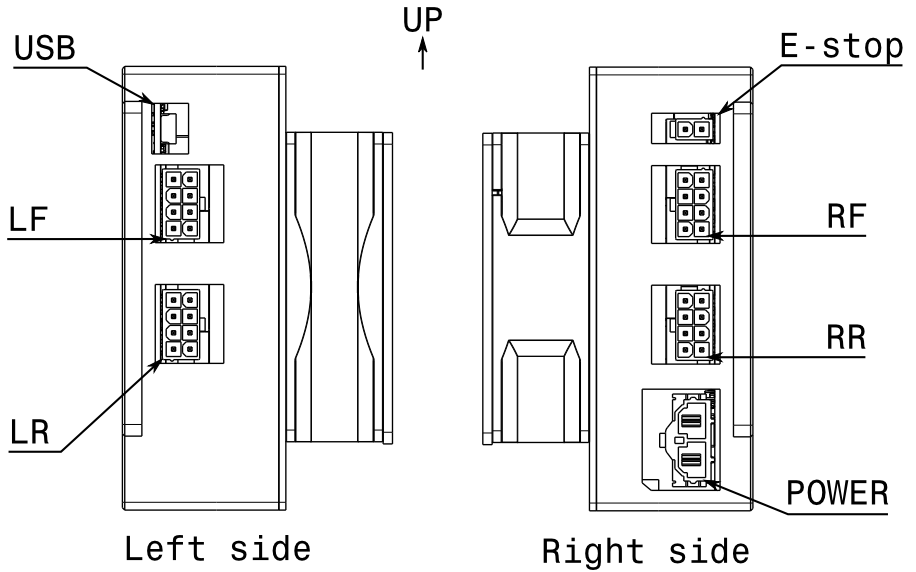

Figure 2: Ports on the ECU.

POWER	Low-voltage power input, connect to PSU
USB	Down-stream USB-port, connect to PC
E-stop	Emergency stop input
LF	Left-Front actuator output
LR	Left-Rear actuator output
RF	Right-Front actuator output
RR	Right-Rear actuator output

Table 1: Ports on the ECU.

6 Actuator

The SIMRIG motion system contains four actuators. They are responsible for moving the rig.

The actuator contains a factory calibrated position sensor. Do not disassemble.

Do not disconnect actuator during use or when powered.

Input voltage	24 V DC
Travel	70 mm
Speed	100 mm/s
Accuracy	0.1 mm
Connector	Molex 8-pin, power and data
Max load	175 kg (SR1), 225 kg (SR2), 250 kg (SR3) when distributed equally over four actuators

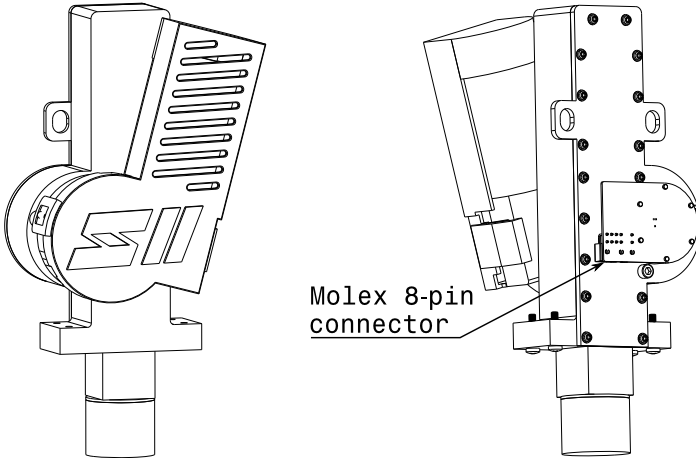

7 Power Supply Unit

The *Power Supply Unit* (PSU) is responsible for converting mains voltage into 24 V DC.

Locate with the SIMRIG logo facing upwards in a well-ventilate position away from your rig.

Do not operate above 5000 m from sea level. Do not operate above 40°C. Do not cover. Do not mount on rig. Do not place under rig. Do not disassemble.

The PSU contains an automatic shutoff feature if overload or overheat is detected. Unplug the PSU, investigate the issue, then re-plug the PSU to recover from the fault.

Input voltage	110-230 VAC
Input frequency	50-60 Hz
Efficiency	95 %
AC current	500 W: 4.8 A @ 110 VAC, 2.6 A @ 230 VAC 750 W: 7.5 A @ 110 VAC, 3.8 A @ 230 VAC 1000 W: 9.0 A @ 110 VAC, 6.5 A @ 230 VAC
Mains connector	C13

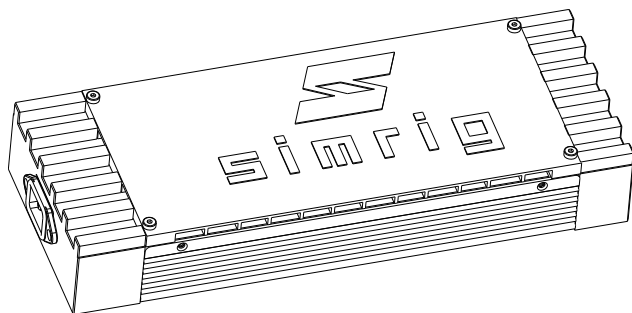

8 Emergency Stop

The emergency stop is an important safety feature. It is required to install the emergency stop. The system will not operate without it.

Activate the emergency stop by pressing the red button. The emergency stop stays active until released. Release the emergency stop by twisting the red button.

The emergency stop should be located in a convenient position that is: close to your hands, in sight, easy to reach, and unobstructed.

Use only the provided emergency stop. Do not modify or try to circumvent the emergency stop. Do not connect in series with other emergency stops.

Test the emergency stop regularly to ensure it works.

8.1 Error Code

The software shows error code 13 if the emergency stop is unconnected or activated. Connect the emergency stop, twist to release, and reset the system to remove the error code.

Twist button to release the emergency stop.

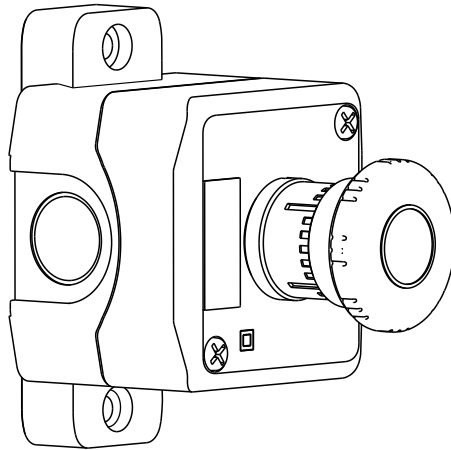

Figure 3: The Emergency Stop.

9 Assembly

Visit www.simrig.se for the latest instructions.

9.1 What you need

- Philips screwdriver (PH2)
- Flat head screwdriver
- Pliers
- Metric Allen/hex keys (3 mm, 5 mm, 6 mm)
- Wrench (8 mm)
- A friend and a pair of saw horses

9.2 Measurements

All measurements are metric unless otherwise noted.

9.3 Before you start

Always disconnect mains power from the power supply prior to maintenance, disassembly, or assembly.

Always disconnect USB from ECU prior to maintenance, disassembly, or assembly.

Many screws are attached to plastic. Tighten gently. Less force is better.

Partially assemble your aluminium rig. Leave all accessories off.

T-nuts can be inserted directly into a slot. Push into slot and twist into place.

9.4 Install the actuators using 780x20x20 aluminium profiles

The SIMRIG actuators attach to your rig using 20x20 mm aluminium profiles and plastic support brackets. The included profiles are 780 mm long. They work for rigs that are up to 620 mm wide.

Start by attaching the 20x20 profiles to your rig. For ease of access, turn the rig upside-down. Set the rig on spacers (such as saw horses) to lift it at-least 30 cm off the floor. Attach the four 20x20 profiles to the bottom of your rig. Space them according to this figure:

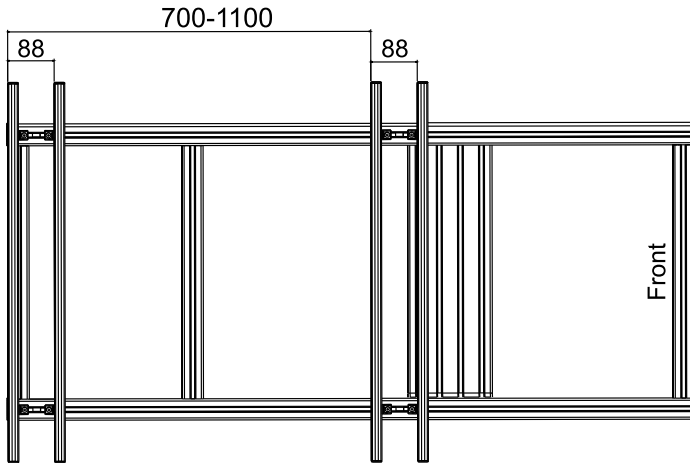

Figure 4: Aluminium rig as seen from below.

You need to move the uprights if they are located directly above a 20x20 profile (as in the figure above) to avoid interference with the actuator. Often you can adjust the distance between the 20x20 profiles instead of moving the uprights.

In our experience the 20x20 profiles are most often mounted behind of the uprights. But for P1-X and similar they are mounted in-front.

Insert a T5M5 T-nut and a T8M5 T-nut as indicated below. Repeat this step eight times; twice for each 20x20 profile.

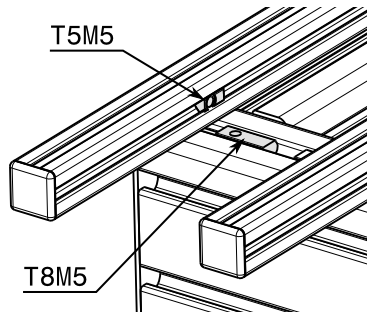

Figure 5: Insert T-nuts in your rig and 20x20 profiles.

Use a M5x8 and a M5x14 mm screw to hold the angle bracket in place. Repeat this step eight times; twice for each 20x20 profile.

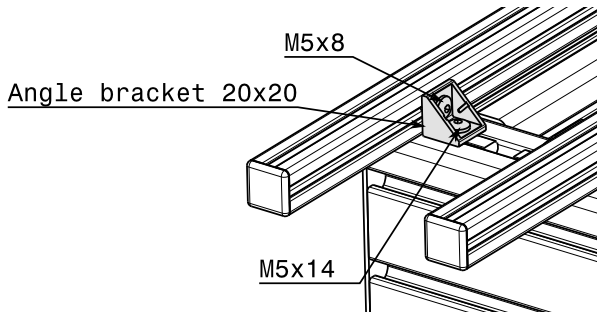

Figure 6: Attach the 20x20 angle bracket on a single profile. Attach eight angle brackets in total. Break off two tabs.

Brake off two alignment tabs on each 20 mm bracket. Use a screwdriver. Twist until the alignment tabs break off.

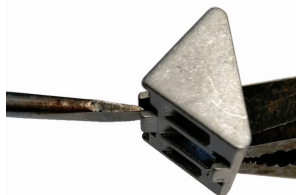

Figure 7: Remove the alignment tabs when attaching two perpendicular profiles.

Insert two T5M5 T-nuts into each 20x20 profile. Repeat this step eight times; twice for each 20x20 profile.

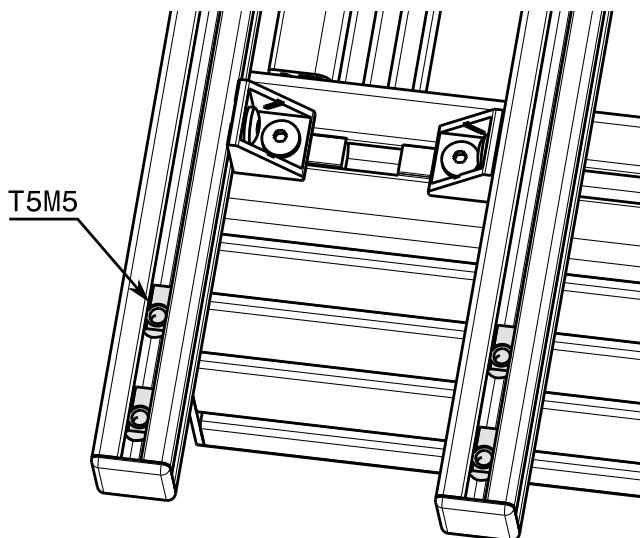

Figure 8: Insert T-nuts in the profiles. The actuator will attach to these later.

Attach the actuator using four M5x25 mm screws. Move the 20x20 profiles to fit the actuator's width. Mount the actuator with the SIMRIG S-logo facing outwards away from the rig:

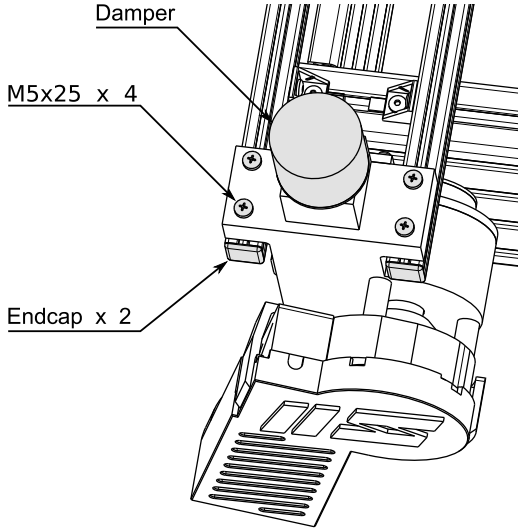

Figure 9: An actuator attached to the 20x20 profiles. The rig is upside-down.

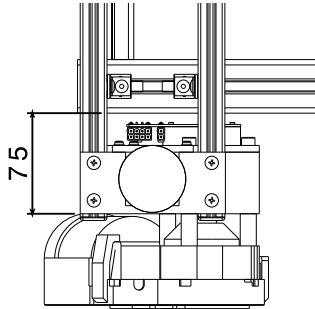

Figure 10: Approximate spacing between rig and actuator.

Attach the end-caps to the 20x20 profiles.

Attach the vibration damper.

Do not use the SIMRIG motion system without the vibration dampers attached.

At this point all four actuators should be attached to your rig.

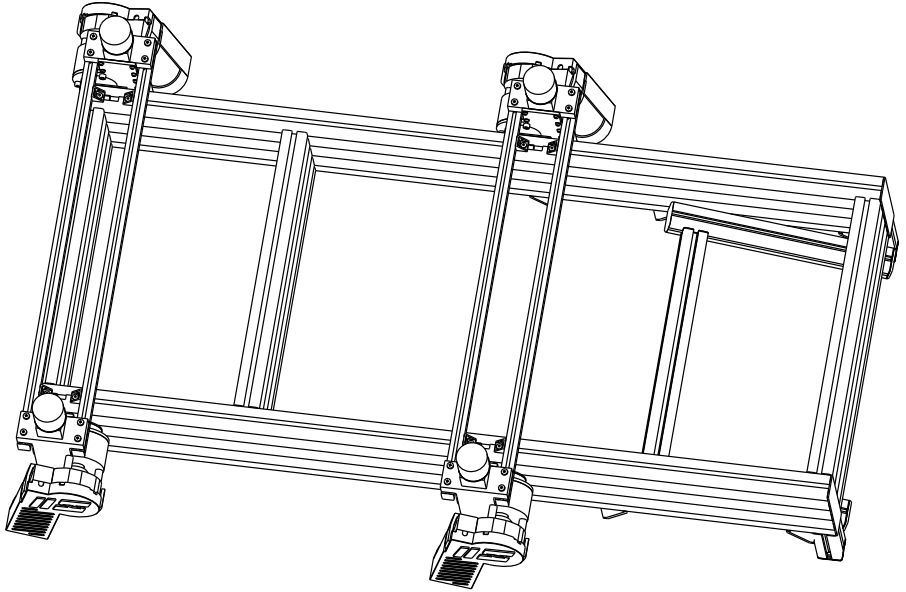

Figure 11: All four actuators are attached to the rig. The rig is upside-down.

9.4.1 Turn around

Turn the rig around. Set the rig on spacers (such as saw horses) to lift it at-least 30 cm off the floor. One or more actuators may be partially extended or retracted. This is fine.

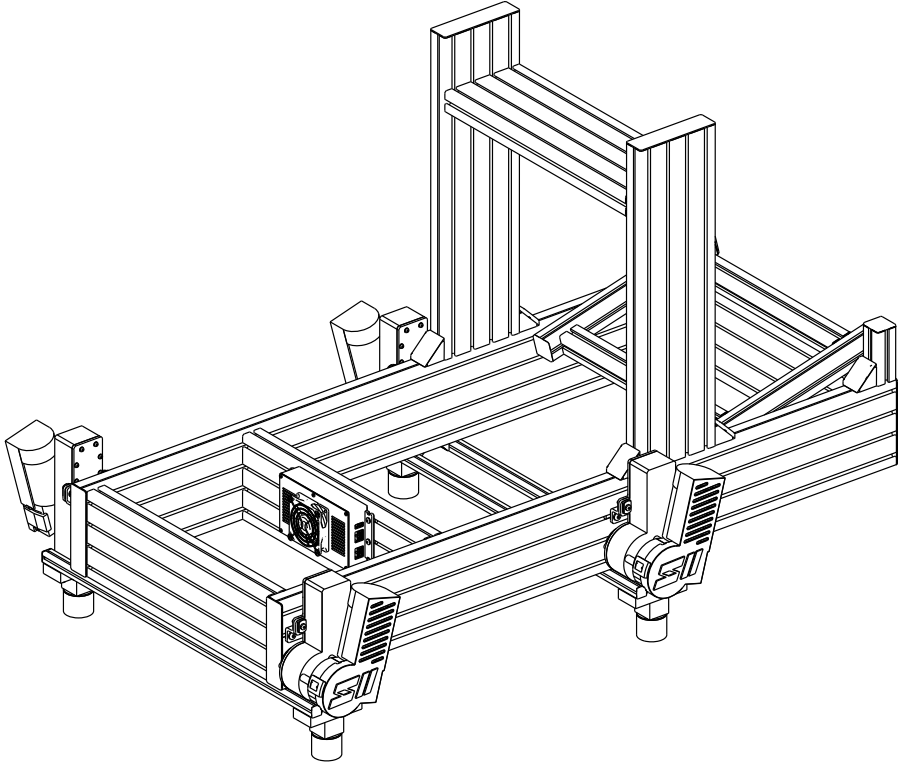

Figure 12: Rig viewed from rear. ECU mounted with USB-port to the left.

9.4.2 Install the support brackets for 120x40 and 160x40 rigs

It is time to prepare the installation of the support brackets. This process is dependent on your rig.

Insert a T8M8 above each 20x20 profile. Use the third slot from the bottom. Repeat this step eight times.

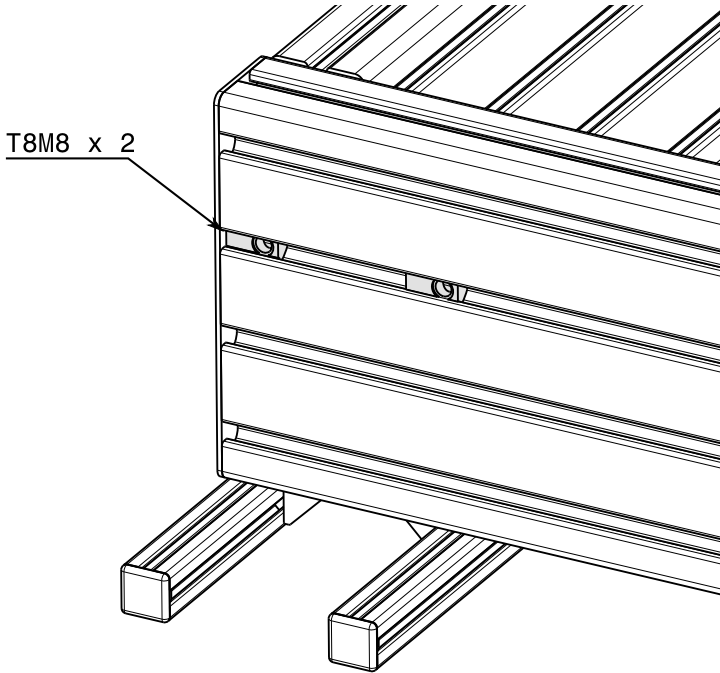

Figure 13: Insert T-nuts that attach to the support bracket.

Attach the support using two M8x16 mm bolts. Repeat this step four times.

Leave the M8x16 bolts loosely attached until the alignment is known.

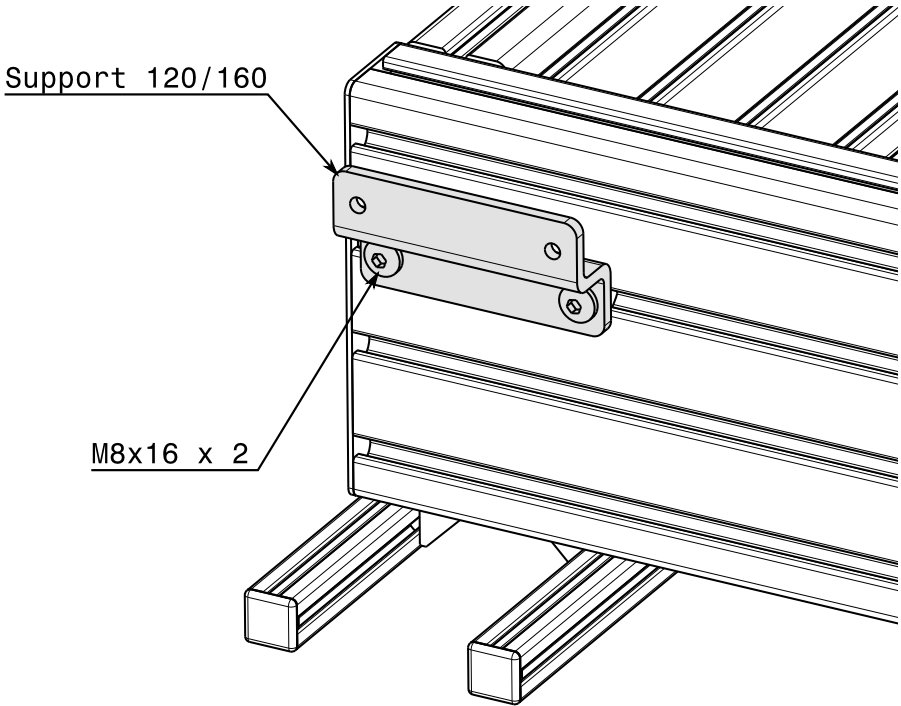

Figure 14: Attach the support bracket.

Attach each actuator to its support bracket using a M5x25 mm screw, a M5 nut, a washer, and a plastic spacer. You will need to adjust the position of the support bracket to align with the actuator.

Each actuator is attached to the support bracket with two M5x25 mm screws; one on each side.

Repeat this step eight times; twice for each actuator.

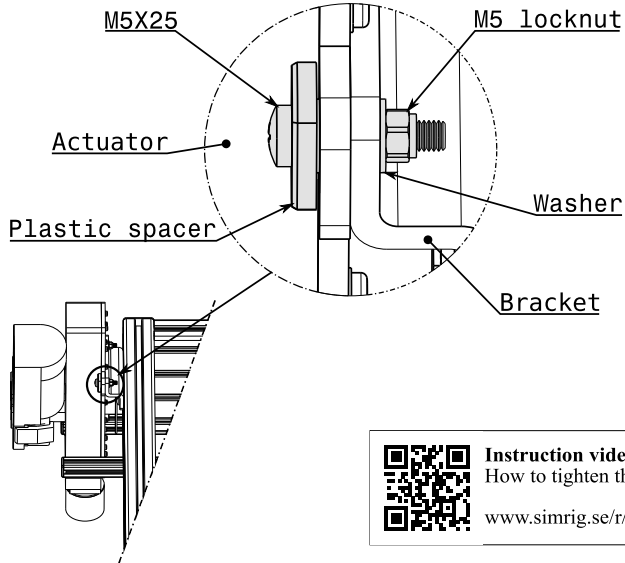

Figure 15: This hardware is required to attach an actuator to its support bracket.

Congratulations! All actuators are now firmly attached to the rig.

Go over all screws and nuts attached so far and tighten them. Tighten gently if the screw attaches to a plastic part.

9.4.3 Install the support brackets for for 80x40 and 40x40 rigs

Insert two T8M8 T-nuts below each actuator. Repeat this step four times; once for each actuator.

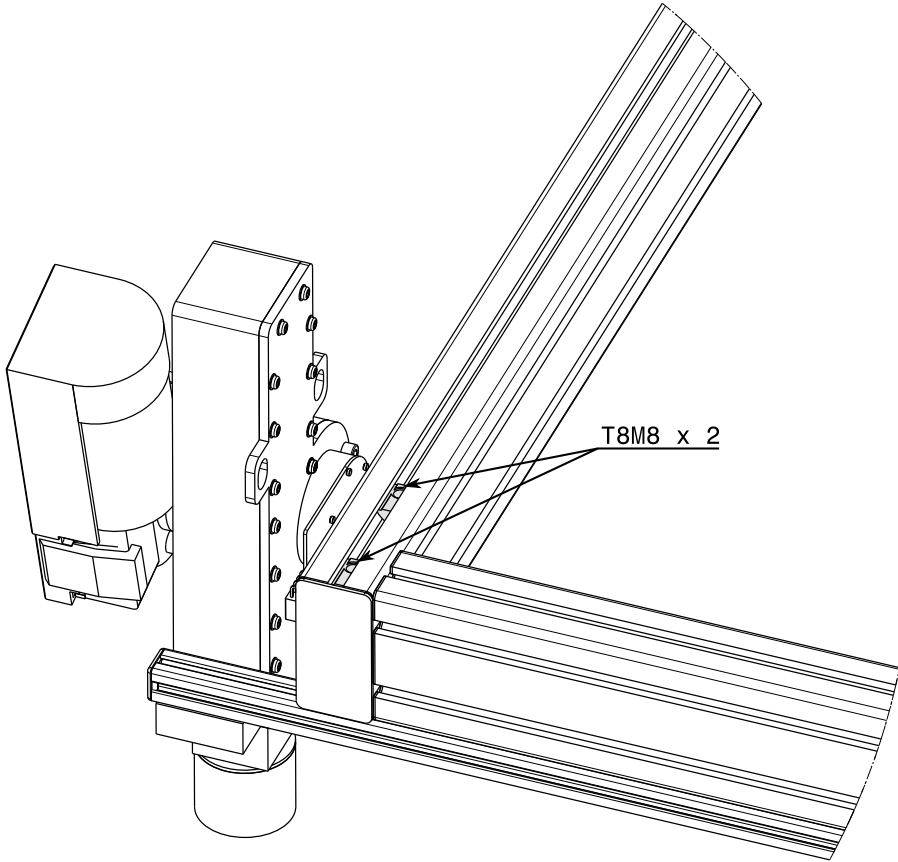

Figure 16: Two T8M8 are inserted in-front of an actuator.

Use the following hardware to attach the support to the rig and the actuator to the support. Repeat this step four times; once for each actuator.

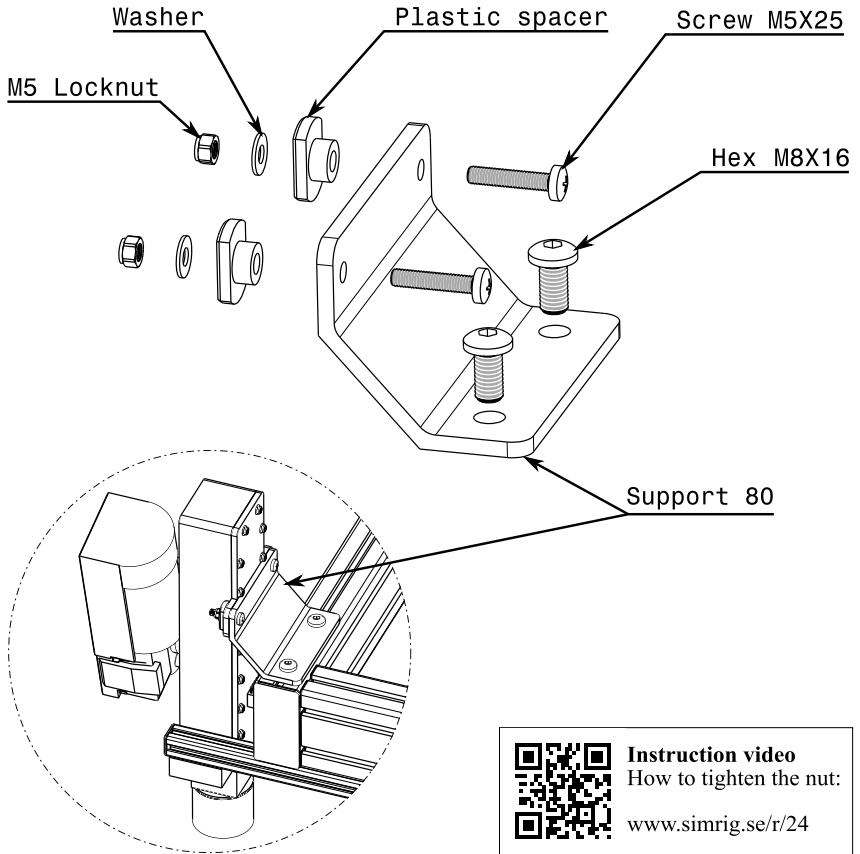

Figure 17: Two T8M8 are inserted in-front of an actuator.

Congratulations! All actuators are now firmly attached to the rig.

Go over all screws and nuts attached so far and tighten them. Tighten gently if the screw attaches to a plastic part.

9.5 Install the actuators using the EasyBracket

This section describes how to attach the SIMRIG actuators to your rig using the EasyBracket and plastic supports. The EasyBrackets are pre-installed on the actuators.

Start by lifting the rig off the floor. Set the rig on spacers to get at-least 15 cm of clearance to the floor.

Our goal is mounting the actuators in a rectangle. With the rear actuators as far back as possible. Space them according to this figure:

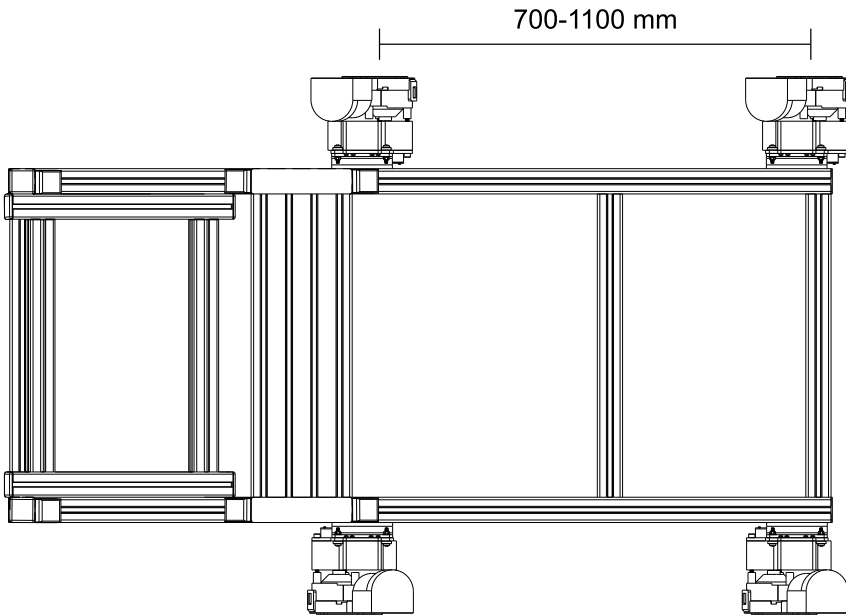

Figure 18: Aluminium rig as seen from above.

On some rigs, you may need to move the uprights if they interfere with the actuators. Alternatively, consider mounting the actuators in-front of the uprights. Prefer mounting them towards the front of the rig to avoid stability issues.

Some assembly is required before the actuators are attached to the rig.

The first step is attaching the vibration dampers. Attach a damper to the bottom of each actuator.

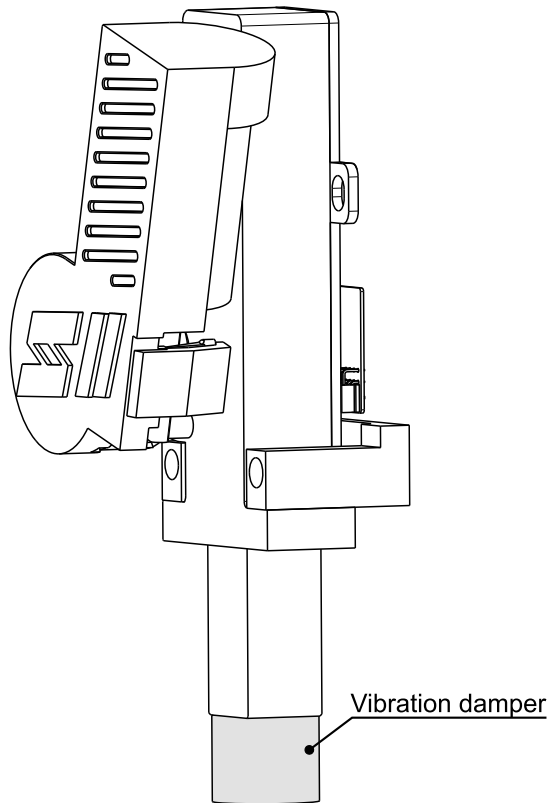

Figure 19: The damper threads into the bottom of the actuator.

The next step depends on your rig. The plastic support brackets are tailored for its size. Their attachment is also different.

9.5.1 Instructions for 40x80 rigs

Attach a plastic support bracket to each actuator using the hardware as shown below:

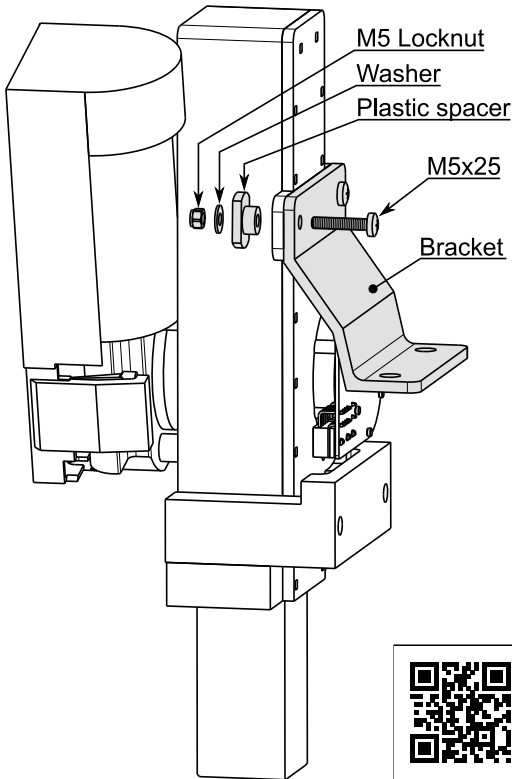

Figure 20: Attaching a 40x80 support bracket to an actuator.

The bracket is held in place with two M5x25 screws, two spacers, two washers, and two locknuts. The figure only shows one side. Don't overtighten the screws.

Tip: Attach one end of the 8-pin cable to the actuator now when it's easy to reach. See 9.8.3 for details.

Prepare to mount the actuators to the rig by inserting four M8T8 T-nut

at each actuator position; refer to Figure 18. Insert two T-nuts in the top slot and two in the lowest slot. These T-nuts hold the actuator.

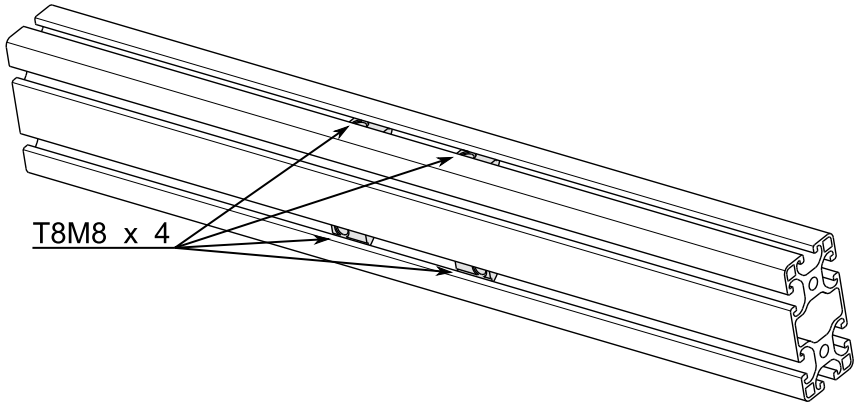

Figure 21: Four M8T8 T-nuts are inserted into the 40x80 profile to hold the actuator.

Align the actuator using the plastic support bracket and the two T-nuts in the top slot. Thread two M8x16 bolts through the plastic support bracket. If done correctly, the actuator is held in-place. Then put a Nordlock washer on each M8x80 bolt and insert them through the bottom of the EasyBracket.

Pay close attention to the Nordlock washers. They come in two parts. It is paramount that both parts are present and correctly oriented with the coarse groves inwards and the fine groves outwards.



Figure 22: A Nordlock washer is split down the middle. Make sure you have both parts.

Take your time and thread the M8x80 bolts onto the T-nuts before tightening them to 24Nm. Afterwards, go back and tighten to top two M8x16 bolts.

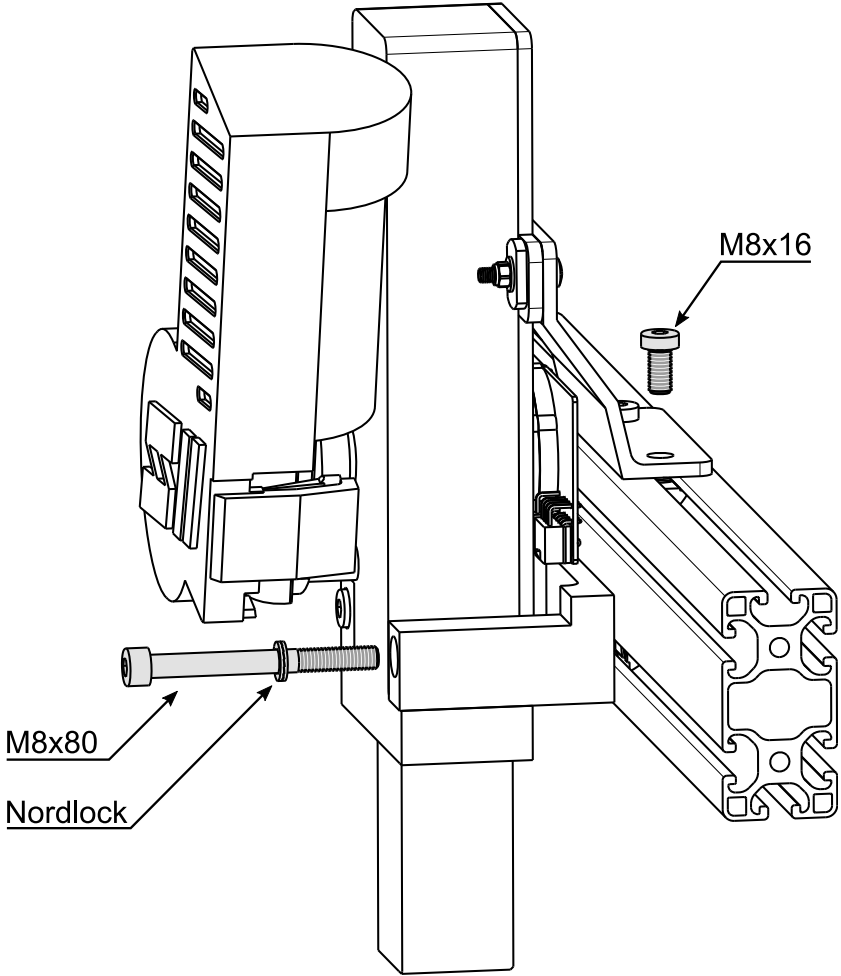
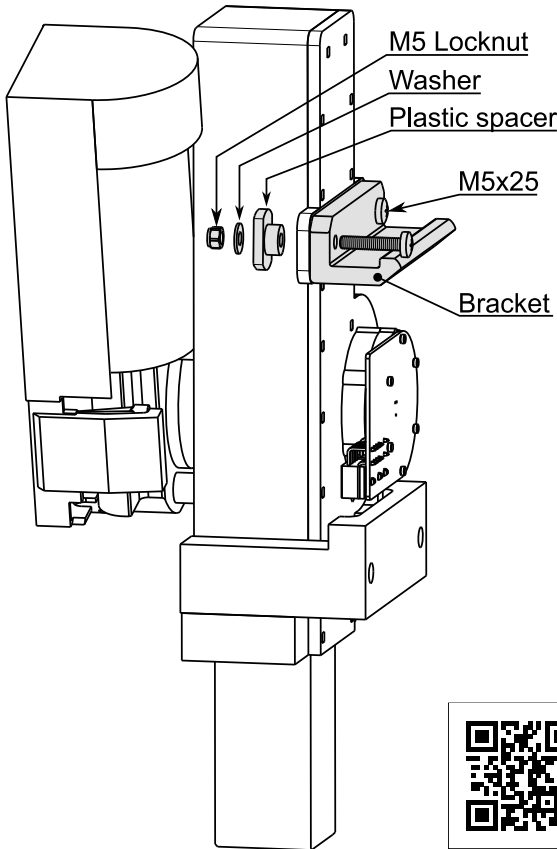

Figure 23: Two M8x80 bolts, two Nordlock washers, and two M8x16 bolts are used to mount the actuator.

9.5.2 Instructions for 40x160 rigs

Attach a plastic support bracket to each actuator using the hardware as shown below:



Instruction video
How to tighten the nut:
www.simrig.se/r/24

Figure 24: Attaching a 40x160 support bracket to an actuator.

The bracket is held in place with two M5x25 screws, two spacers, two washers, and two locknuts. The figure only shows one side. Don't overtightened the screws.

Tip: Attach one end of the 8-pin cable to the actuator now when it's easy to reach. See 9.8.3 for details.

Prepare to mount the actuators to the rig by inserting two M8T8 T-nut at each actuator position; refer to Figure 18. Insert the T-nuts into the lowest slot on the profile. These T-nuts hold the actuator.

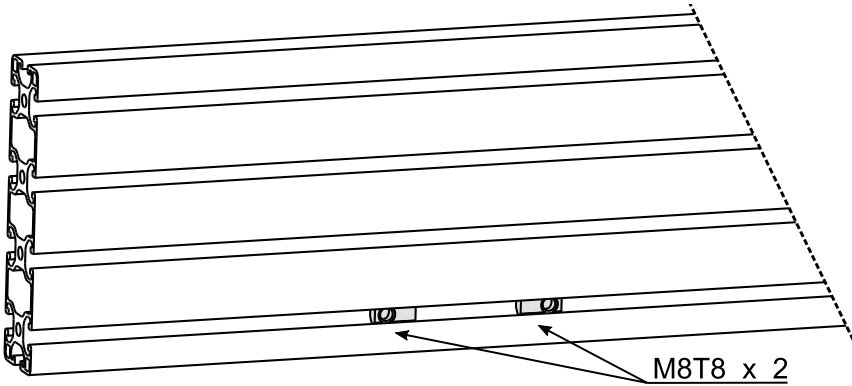

Figure 25: Two M8T8 T-nuts are inserted into the the lowest slot in the 40x160 profile.

Tilt the actuator forwards and insert the plastic support bracket into the top-most slot on the profile. Then carefully lower the bottom of the actuator until the EasyBracket touches the profile. If done correctly, the actuator is held in-place by the plastic support bracket.

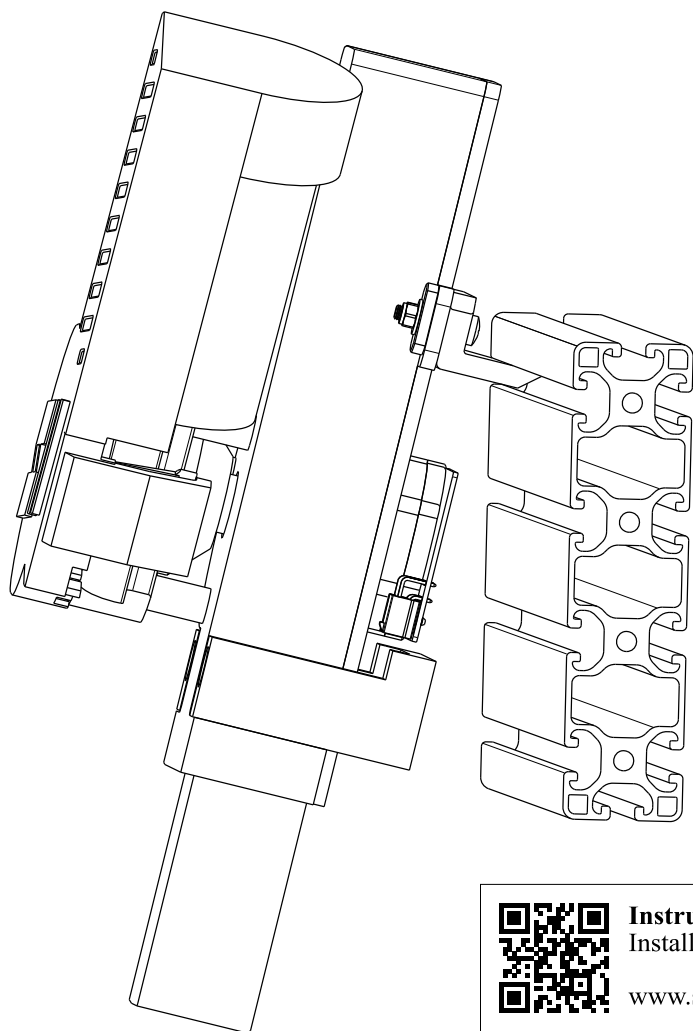

Figure 26: Angle the actuator and insert the plastic support bracket into the top-most slot.

Align the actuator with the T-nuts. Then put a Nordlock washer on each M8x80 bolt and insert them through the bottom of the Easy-Bracket.

Pay close attention to the Nordlock washers. They come in two parts. It is paramount that both parts are present and correctly oriented with the coarse grooves inwards and the fine grooves outwards.



Figure 27: A Nordlock washer is split down the middle. Make sure you have both parts.

Take your time and pre-thread the bolts to the T-nuts before tightening them to 24 Nm.

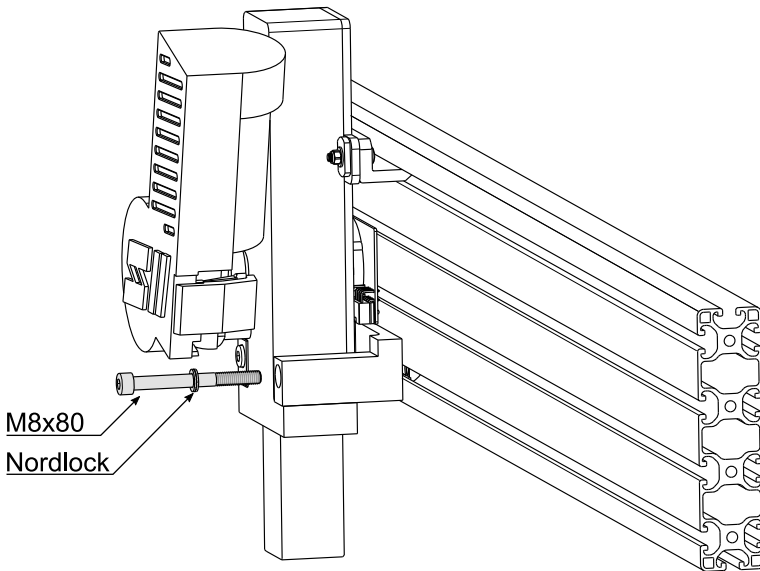

Figure 28: Two M8x80 bolts and two Nordlock washers are used to mount the actuator.

9.5.3 Alignment and adjustments

It is important to keep all four actuators in a rectangle. Use a tape measure to verify that all actuators are positioned correctly.

Measure the distance from the rear of the rig to the rear actuators. It should be the same distance on both sides.

Measure the distance from the front of the rig to the front actuators. It should be the same distance on both sides.

Adjust the actuators as necessary.

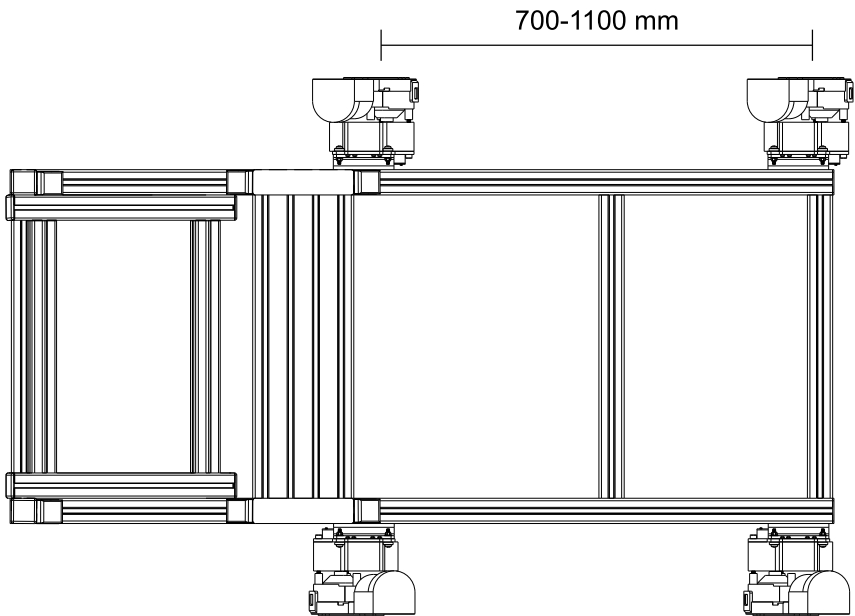

Figure 29: These actuators are mounted in a rectangle.

9.6 Install the Electronic Control Unit

Place the *Electronic Control Unit* (ECU) under the seat and attach it to the frame. Orient it with the lid of the ECU facing backwards with the USB-port on the left side.

Attach the ECU to the frame with either:

- tie straps,
- or two M5x14 mm screws and two T5M8 T-nuts.

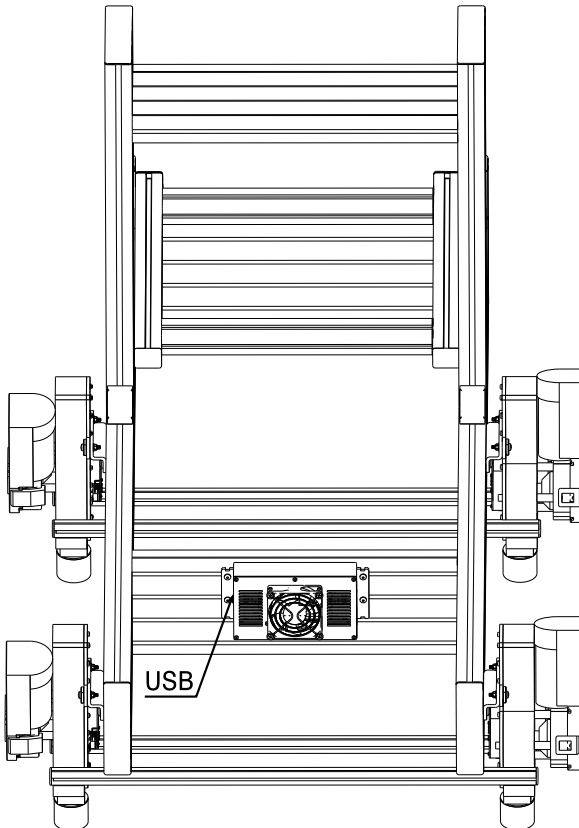

Figure 30: Rig viewed from rear. ECU mounted with USB-port to the left.

9.7 Install the Emergency Stop

Attach the emergency stop to your rig using the supplied M5 screws and T-nuts. Locate the emergency stop in a easy-to-reach position.

First, insert two T8M5 T-nuts into your rig at an easy to reach position. Then, attach the emergency stop to the rig using two M5x25 screws.

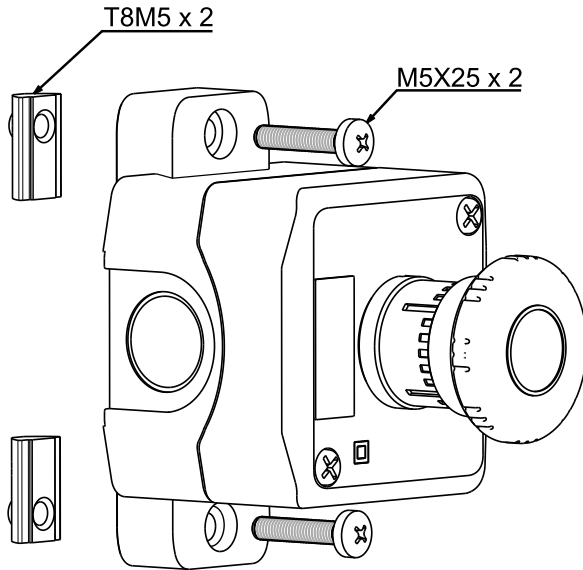

Figure 31: Two T8M5 T-nuts and two M5x25 screws are used to attach the emergency stop.

Connect the emergency stop to the *E-stop* port on the ECU. See Figure 2 for port names.

9.8 Electrical

There is a total of six cables to connect:

- four actuator cables from the ECU to each actuator,
- a USB-cable from the ECU to the PC,
- a low-voltage power cable from the power supply to the ECU,
- a high-voltage cable from the mains power socket to the power supply.

Always disconnect mains power from the power supply prior to maintenance, disassembly, or assembly.

Always disconnect USB from ECU prior to maintenance, disassembly, or assembly.

9.8.1 Attach USB-cable

Connect the USB-cable to your PC and to the USB-port on the ECU. See Figure 2 for port names.

Use a USB 2.0 port or faster. Avoid using a USB-hub.



Figure 32: A USB-cable.

9.8.2 Attach low-voltage power cable

Disconnect PSU from mains power.

Connect the low-voltage power cable to the black connector in the bottom-right corner of the ECU. See Figure 2 for port names. Then connect the other end the PSU.



Figure 33: An low-voltage power cable.

9.8.3 Attach actuator cables

Connecting the four 8-pin cables between the ECU and the four actuators.

While facing the ECU lid (with the USB port on the left side) make the following connections:

- Left Front (LF) motor to upper left port
- Left Rear (LR) motor to lower left port
- Right Front (RF) motor to upper right port
- Right Rear (RR) motor to lower right port



Figure 34: An 8-pin Molex cable.

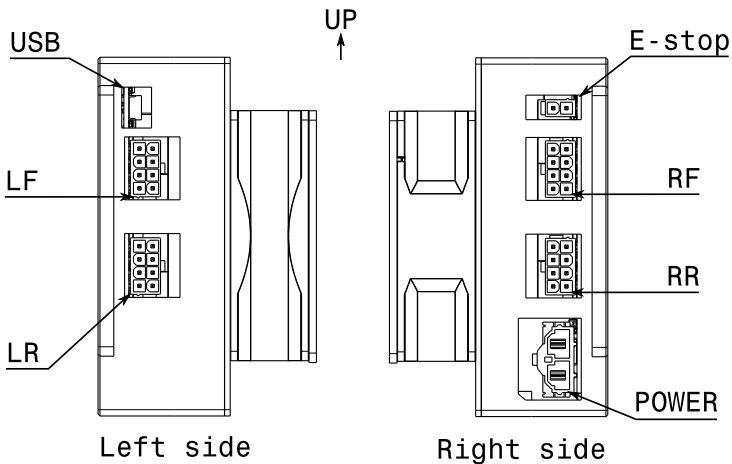

Figure 35: Ports on the ECU.

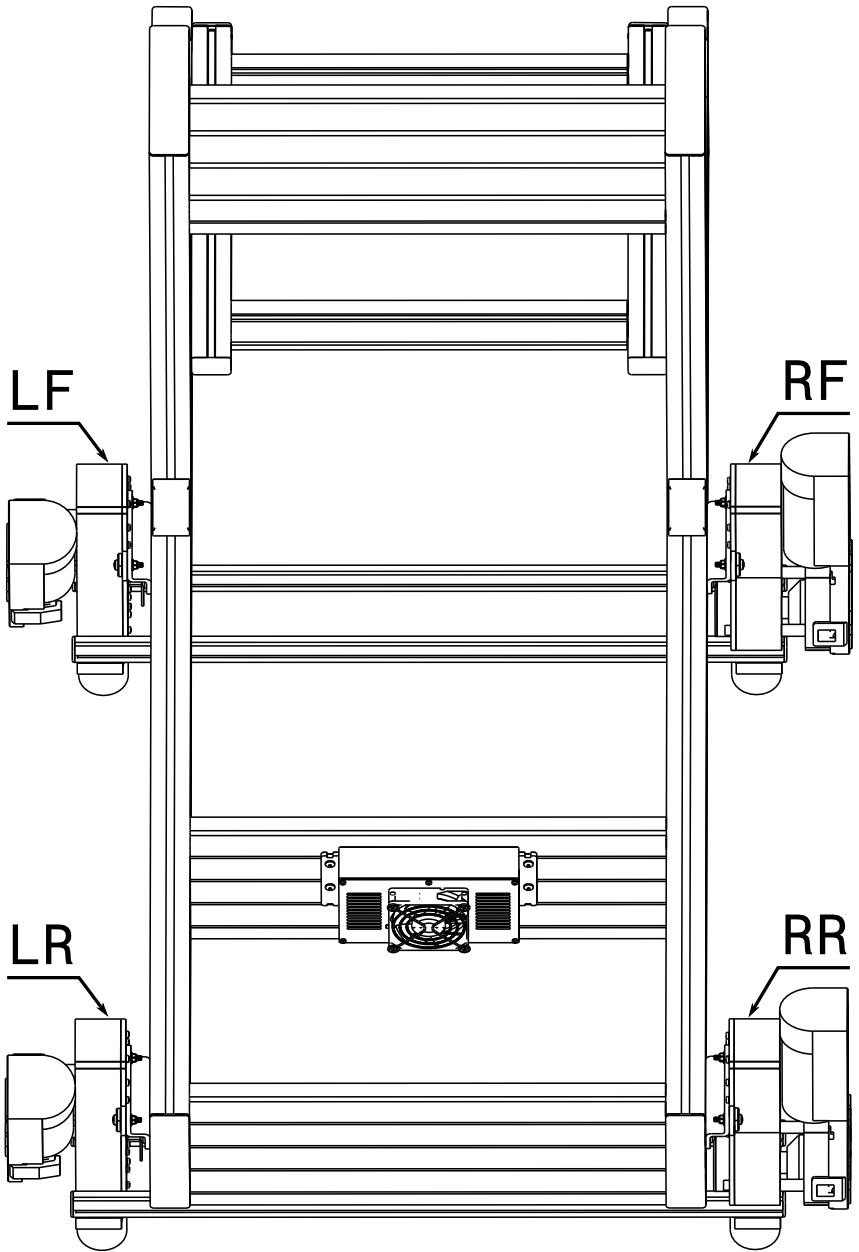

Figure 36: The names of the four actuators. Connect to the corresponding port on the ECU using 8-pin Molex cables.

9.8.4 Cable management

Do not modify or disassemble the cables. Do not add sleeves.

Good cable management is very important for longevity. Wear and tear in the connectors is avoided with proper strain relief.

It is absolutely paramount to attach each cable to a solid attachment point close to its connector. A good example is using cable ties wrapped around an aluminium profile. See Figure 37 below.

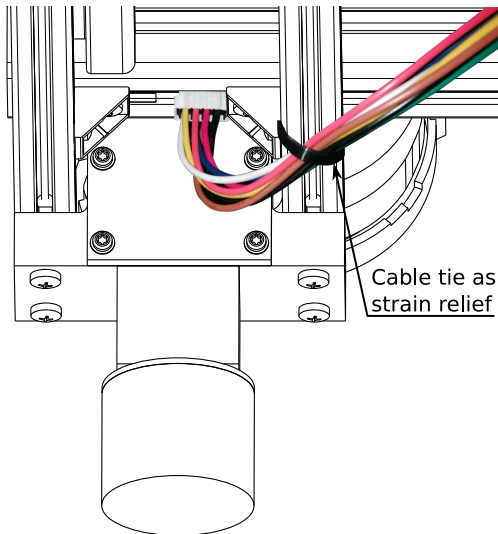

Figure 37: A cable tie firmly attaches the cable close to its connector. The cable is locked in place, reducing wear and tear on the connector.

A motion system moves a lot for long periods of time. Without proper strain relief this motion is transferred to cables and connectors; wearing them down. All cables must be locked in place; to reduce their motion as much as possible. This is especially important close to connectors.

For systems using the EasyBrackets: add one of the included cable clips

close to each actuator. Then use a cable tie to firmly lock the cable in place.

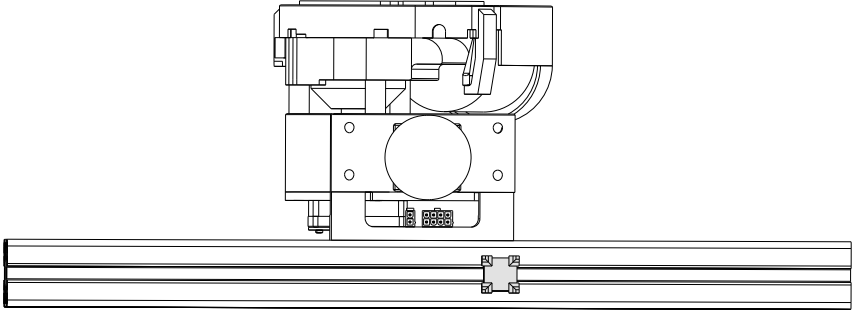

Figure 38: Use the included cable clips to manage the cables.

Install cable ties close to these locations:

- on the Molex cable as it attaches to the actors (see Figure 37,)
- on the Molex cable as it enters the ECU,
- on the Power cable as it enters the ECU,
- on the USB-cable as it enters the ECU,
- on the E-stop cable as it enters the ECU.

Proper strain relief also includes leaving slack between the first clamping point and the connector. In the picture above the cable is bow-shaped. It does not take the shortest path between the connector and the clamping point. Instead there is extra cable length beneath the connector.

9.9 Adjustments

At this stage you are ready to install the software, run *Axis Tester*, and adjust the load distribution.

It is important to spread the load equally over the front and rear actuators. This greatly improves the lifespan and performance. We achieve this by adjusting the load distribution.

Use the software to measure the load distribution as described in Section 10.5. Then move the seat back or forth until the distribution is as even as possible. Sometimes it is necessary to move the steering wheel assembly and/or the pedals. It also helps to move the actuators. For example, move the rear actuators forwards to transfer load from the front actuators to the rear.

Strive for 50 % load on the front actuators and 50 % load on the rear actuators; ± 5 % is fine.

10 Software and Drivers

Visit www.simrig.se/sw to download software and drivers.

Take note of serial number located on ECU. There should be a label similar to this:

SIMRIG SR2	SIMRIG AB
SN: XXXXXXXX	SWEDEN

The serial number is located in the bottom left corner (XXXXXXXX in the example above.)

Download and install SIMRIG Control Center. During installation make sure to also install these software dependencies:

- FTDI Drivers
- Visual Studio Runtime

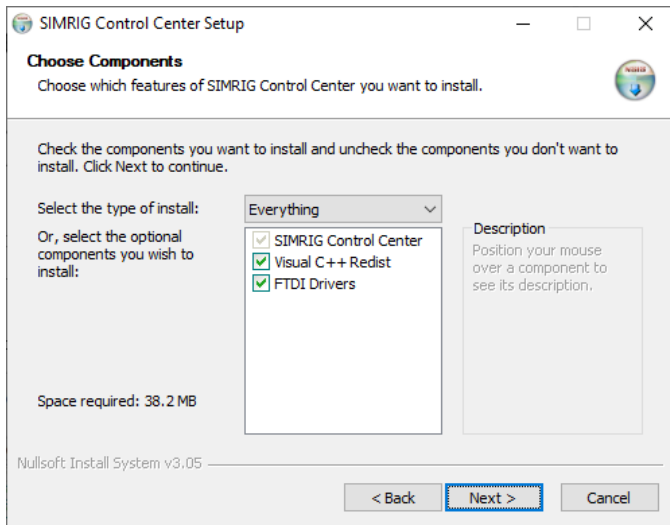

Figure 39: Installer for SIMRIG Control Center.

10.1 First start

Go ahead and start SIMRIG Control Center. It must always run in the background while using the motion system. This is what you will see when you start the program for the first time:

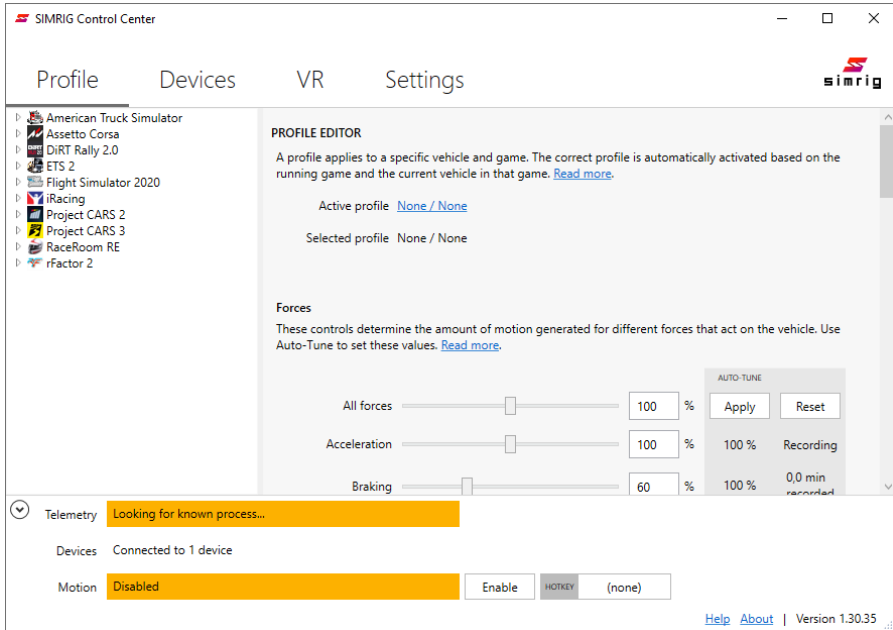

Figure 40: SIMRIG Control Center when first started.

We have a single device connected to our system. This is apparent by the box at the bottom of the screen and the message: "Connected to 1 device".

Motion is disabled at startup. You must manually enable motion by pressing the *Enable* button.

No telemetry is currently available as indicated by the "Looking for known process..." message. This message goes away when you launch a supported game.

Telemetry refers to the motion data generated by games. All supported games output telemetry that tells the motion system how to move and when.

The software comes pre-configured with a selection of vehicles. It is recommended to try one of these the first time:

Game	Vehicle
Assetto Corsa	BMW M3 E30 Group A
Assetto Corsa Competizione	Porche 911 Cup
iRacing	Global Mazda MX-5 Cup Ferrari 488 GT3
Microsoft Flight Simulator	Cessna 152
Project CARS 2	Chevrolet Camaro Z/28 '69
Race Room Racing Experience	Volvo 240 Turbo

Table 2: Pre-configured games and vehicles that are known to work out of the box.

10.2 Game configuration

Some games do not work directly. They require setup. See the online instructions manual at www.simrig.se/sw for more details.

10.3 Profiles

Each vehicle is assigned a unique profile. The purpose of a profile is to control how simulated forces are converted into motion. Since each car behaves in a different way (some are fast, some are slow) each car requires a unique profile and unique settings. Getting the profile right and tuned correctly is very important; it determines the motion system's behavior and response to in-game events.

The most important in-game event is vehicle acceleration. Most profile settings therefore deal with acceleration and the system's sensitivity to acceleration in different directions.

The software's *Auto Tune* function is designed to generate a baseline profile by recording telemetry data while you drive. The algorithm can generate a profile by analyzing the forces that act on the car. The resulting profile tries to maximize the range of motion while minimizing clipping.

See the online instructions manual at www.simrig.se/sw for more details.

10.4 Axis tester

It is possible to test the system without a game using the *Axis Tester*. This tool is accessible from the *Devices* page:

1. Open the *Devices* page
2. Locate your SIMRIG motion system
3. Press *Device options*
4. Press *Launch Axis Tester*

10.5 Load estimator

It is possible to measure the system load distribution using the *Load Estimator*. This tool is accessible from the *Devices* page:

1. Open the *Devices* page
2. Locate your SIMRIG motion system
3. Press *Device options*
4. Press *Launch Load Estimator*

Be seated while the *Load Estimator* runs.

11 Maintenance

Always disconnect mains power from the power supply prior to maintenance, disassembly, or assembly.

Always disconnect USB from ECU prior to maintenance, disassembly, or assembly.

11.1 Cleaning

Keep clean with dry cloth. Do not use cleaning products that are electrically conductive such as water and metal brushes.

11.2 Periodic checks

Periodically check all screws. Make sure they are tight.

Periodically check all cables. Make sure all cables are secured tightly to your rig; to avoid chafing and unnecessary mechanical wear. Make sure no cables are kinked or strained.

Periodically check all connectors. Make sure they are firmly seated in their socket.

Periodically check the emergency stop. Press the emergency stop and verify that it works as intended.

11.3 Fuse replacements

The ECU contains four Mini Blade fuses rated at 7.5 A. Replacements are available at your local automotive parts store. For reference see Little Fuse part nr. *029707.5WXNV*.

12 Technical Support

A detailed instructions manual for SIMRIG Control Center is available online at www.simrig.se/sw.

12.1 Manufacturer

SIMRIG AB

Web www.simrig.se

Email info@simrig.se

Phone **+46 760 22 45 50**

We answer the phone between 9:00 and 16:00 Swedish time (CET.) We speak English and Swedish.